

IONIC COMPOUNDS

DEFINITION

Ionic Compound is formed due to creation of an ionic bond which is the electrostatic attraction between a **cation (+ charge)** and an **anion (- charge)** generally involving a metal and a non-metal.

NOMENCLATURE

Charges are written because ions are either positive or negative.

- Name the **cation first**, followed by the anion
- Anion must end in **ide** (drop the last few letters)
- Roman Numerals must be used for metals with more than one charge (e.g. transition metals)

Ex : NaCl = Sodium chloride

Ex : CuCl_2 = Copper (II) chloride

PROPERTIES

- High melting points
- High boiling points
- Hard and brittle
- Good insulators
- Forms crystals
- Conduct electricity when they are dissolved in water
- Ionic compounds have higher enthalpies of fusion

EXAMPLES

Some examples of Ionic compounds are **Sodium Chloride**, **Lithium Iodide**, **Potassium Iodide** and **Sodium Fluoride**.

SODIUM CHLORIDE (NaCl)

Some of sodium chloride's use includes consumption, production and is **naturally occurring**.



POTASSIUM IODIDE (KI)

Potassium iodide tablets are given to people exposed to high level of radiation.



LITHIUM IODIDE (LiI)

Lithium Iodide is commonly used in batteries, pacemakers and solar power generator.



SODIUM FLUORIDE (NaF)

Sodium fluoride is used in medical treatment, water purification and cleaning solutions.



MOLECULAR COMPOUNDS

FORMED BY A COVALENT BOND, WHICH IS THE SHARING OF ELECTRONS BETWEEN ATOMS INVOLVES TWO NON-METALS

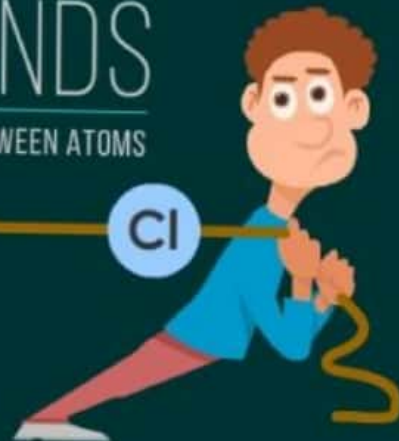

NOMENCLATURE

- Ionic charges cannot be written because it is composed of molecules, not ions.
- Prefix :- mono, di, tri, tetra, penta, hexa, hepta, octa, nona, deca.
- Name the elements in the order listed.
- Use prefixes to indicate the number of each atom of each element (mono can only be used on the second non-metal).
- The first element includes prefix + element name.
- The second element includes the prefix + the element name + ide ending (drop the last few letters).

Eg : hydrogen chloride = HCl

Eg : phosphorus pentachloride = PCl_5

PROPERTIES



LOW
MELTING
POINTS



MORE
FLAMMABLE



NOT
SOLUBLE
IN WATER



SOFTER
AND
SQUISHIER

SOME EXAMPLES OF MOLECULAR COMPOUNDS



DIHYDROGEN
MONOXIDE (H_2O)

Dihydrogen monoxide or water is vital for our survival, used in our daily needs.



SILICON
DIOXIDE (SiO_2)

Silicon dioxide is used for construction and is found naturally in sand and quartz.



CARBON
DIOXIDE (CO_2)

Some uses of carbon dioxide are carbonation of liquids and green house effect.



SULPHUR
DIOXIDE (SO_2)

Sulphur dioxide is used for food preservation and acts as a disinfectant.





HYBRIDISATION



ANALOGY FOR HYBRIDISATION



Four different sized mud balls combine to form equal shaped balls.



Similarly, orbitals of different energy combine to form equal energy orbitals.

HYBRID ORBITALS ARE USED IN FORMING SIGMA BONDS

Formation of CH₄

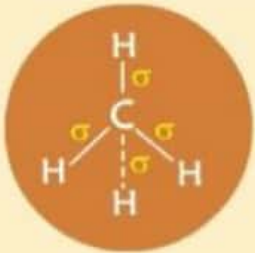

Here carbon needs to form 4 sigma Bonds.

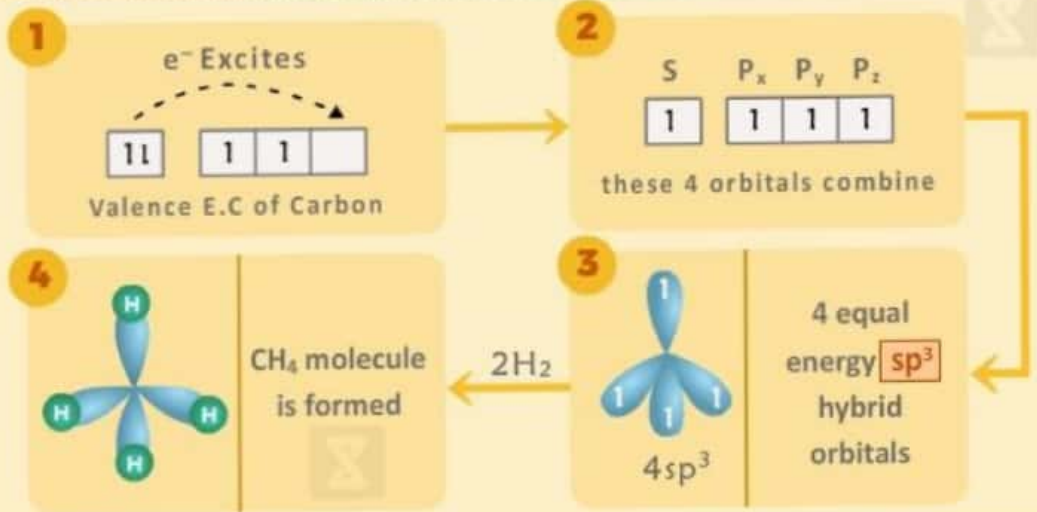

Formation of C₂H₄



Here each carbon needs to form 3 sigma and 1 pi Bonds.

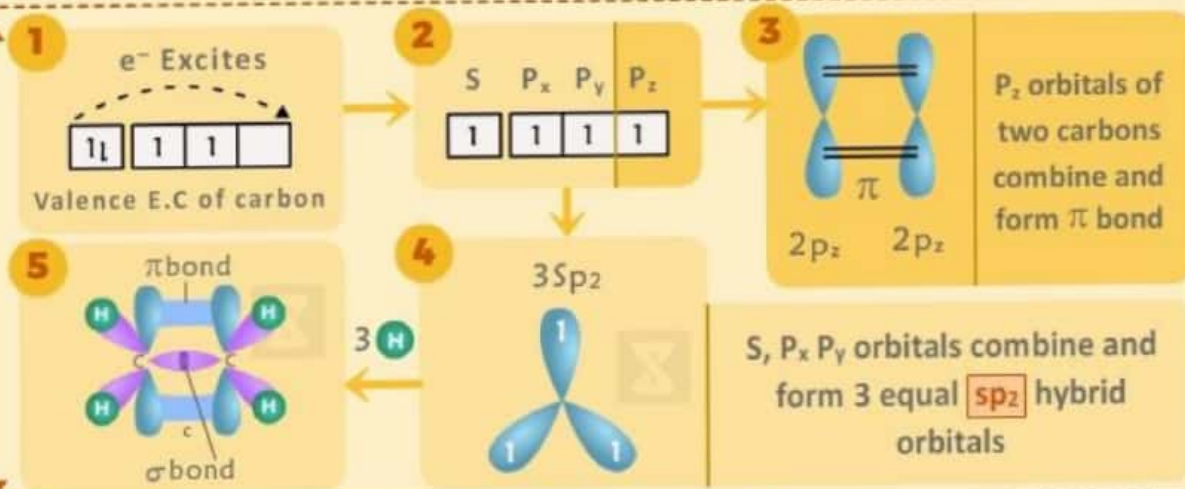

Formation of C₂H₂



Each carbon needs to form 2 sigma and 2 pi Bonds.

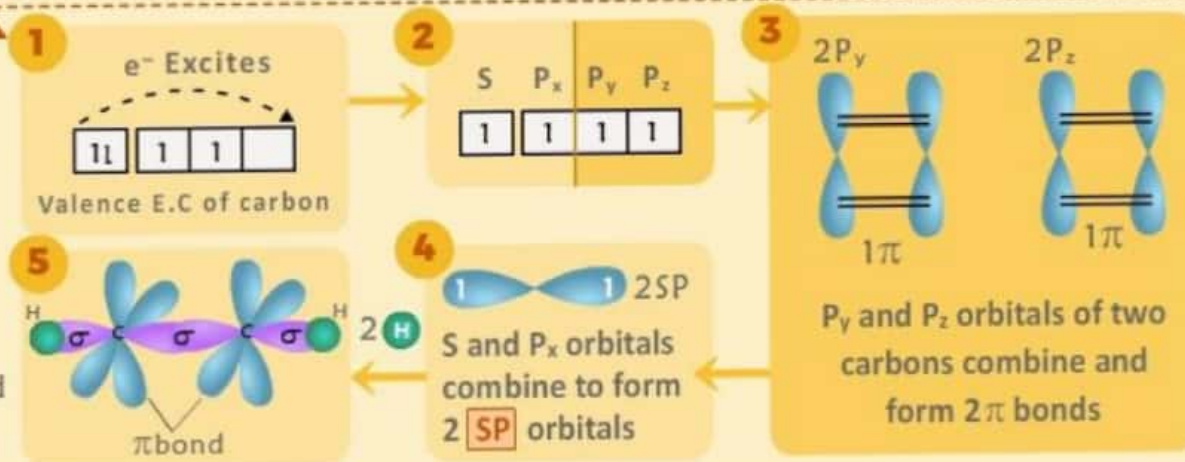

VSEPR & SHAPES OF MOLECULES

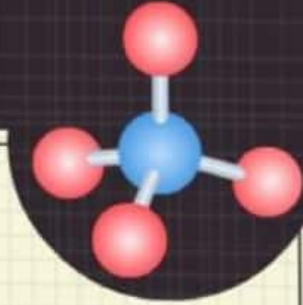

Bonding Pairs & Lone Pairs

Lone pairs in a molecule lie closer to the central atom, hence they repel more than a bonded pair. The order of strengths of repulsion is :

LONE PAIR/LONE PAIR > BONDED PAIR/LONE PAIR > BONDED PAIR/BONDED PAIR

Shapes with different electron Pair : (ep)

2 ep :

Linear



AX_2
2 bond pairs
0 lone pairs

3 ep :

Trigonal-Planar

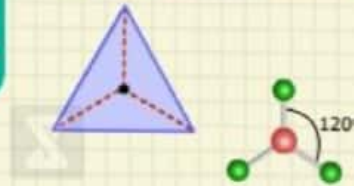

AX_3
3 bond pairs
0 lone pairs

Bent

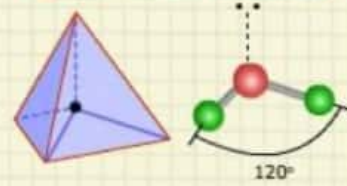

$SrCl_2$
2 bond pairs
1 lone pairs

4 ep :

Tetrahedral

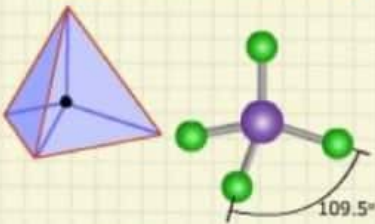

Methane (CH_4)
4 bond pairs
0 lone pairs

Trigonal pyramidal

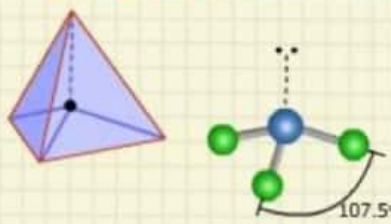

Ammonia (NH_3)
3 bond pairs
1 lone pairs

Bent

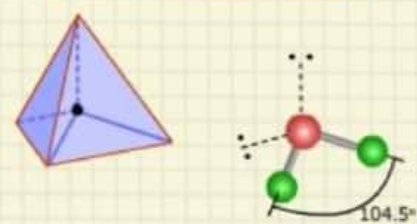

Water (H_2O)
2 bond pairs
2 lone pairs

5 ep :

Trigonal Bipyramidal

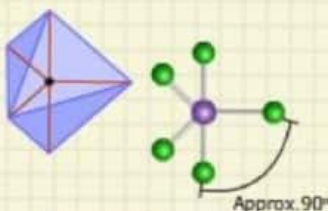

PF_5
5 bond pairs
No lone pairs

See Saw

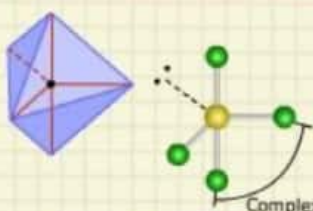

SF_4
4 bond pairs
1 lone pairs

T-Shaped

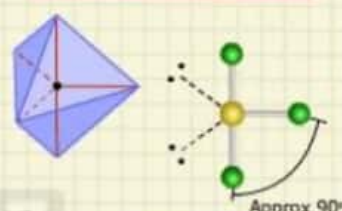

ICl_3
3 bond pairs
2 lone pairs

Linear

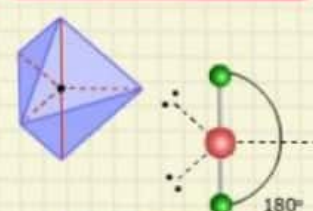

BrF_2^-
2 bond pairs
3 lone pairs

6 ep :

Octahedral

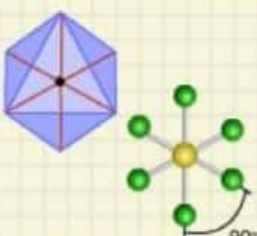

SF_6
6 bond pairs
No lone pairs

Square-pyramidal

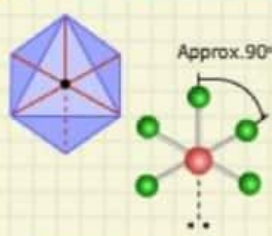

BrF_5
5 bond pairs
1 lone pairs

Square-planar

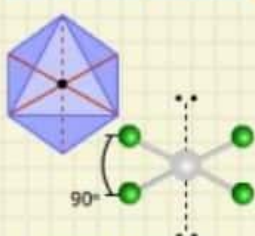

XeF_4
4 bond pairs
2 lone pairs

T-Shaped

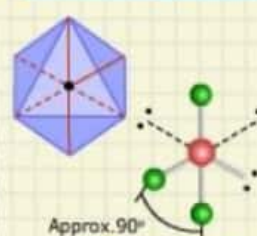

ClF_3
3 bond pairs
3 lone pairs

Linear

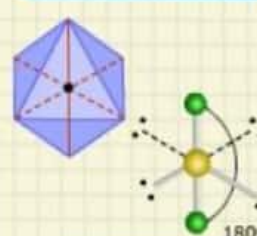

XeF_2
2 bond pairs
4 lone pairs

MOLECULAR ORBITAL THEORY

MOT explains the bonding and stability of Molecules by forming Molecular orbitals

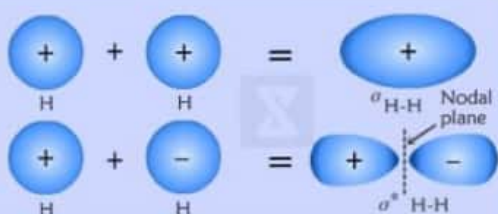

s-orbital of one atom combines with s-orbital of another atom constructively and destructively to form σ and σ^* molecular orbitals.

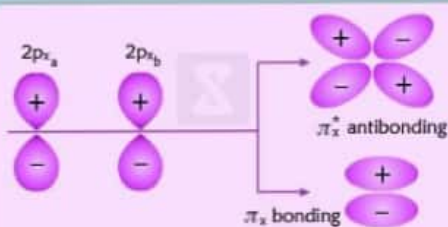

p_x orbital of one atoms combines with p_x of another atom to form σ and σ^* orbitals.

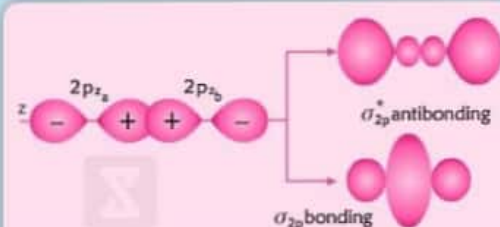

p_y and p_z orbitals combine and forms π and π^* orbitals.

Energy Diagram of Molecular Orbitals

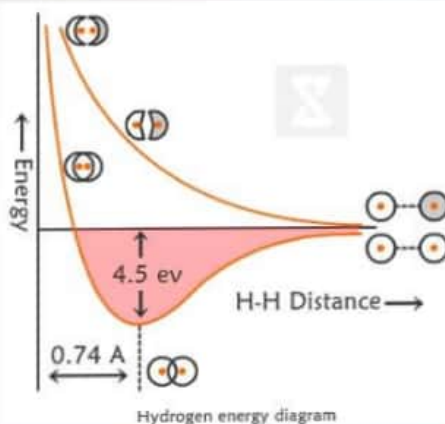
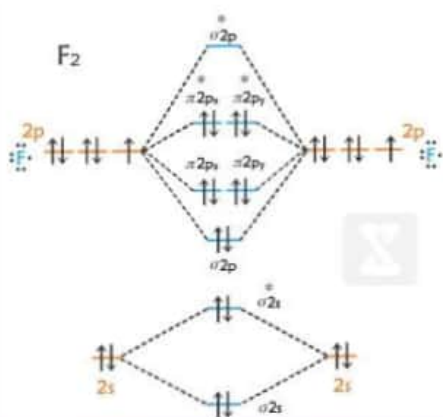

Bond Order

$$\text{Bond order} = \frac{1}{2} \left[\begin{array}{l} \text{Number of} \\ \text{Bond of} \\ \text{electron in} \\ \text{bonding} \\ \text{orbitals} \end{array} - \begin{array}{l} \text{Number of} \\ \text{Bond of} \\ \text{electrons} \\ \text{in anti-bonding} \\ \text{orbitals} \end{array} \right]$$

Bond	H ₂ ⁺	H ₂	He ₂ ⁺	He ₂
Bond Order	1/2	1	1/2	0

The bond order must be **positive non-zero** for a bond to be stable. He₂ has a bond order of zero and that is why the He₂ molecule is not observed.